



GEARGRID Heavy Duty Mobile Hose/SCBA Bottle Storage

Assembly Instructions & Owners Manual

Thank you for choosing the Geargrid Heavy Duty Mobile Hose/SCBA Bottle Storage System. Geargrid is committed to high product quality and your complete satisfaction.

Please read this manual before you start the assembly. Call us at 888-643-6694 if you encounter any assembly or product performance problems.

Before You Begin:

NOTE: Two person assembly is required.

Assembly Preparation:

- Open and remove contents from all boxes
- Check all parts against the parts list
- Organize parts by type
- Locate a clear, level floor
- Lay the shipping carton cardboard on the floor and assemble the unit on it to protect unit from floor damage during assembly.

Tools Required:

- Rubber Mallet
- 3/8", 7/16", 1/2" and 9/16" sockets with ratchet

Warranty Information: GEARGRID Wall Mount Lockers are guaranteed to be free of material and workmanship defects for one full year from the date of purchase. GEARGRID guarantees to repair or replace defective materials, without charge. To file a claim call our Customer Service department at 888-643-6694. If product return is necessary your Customer Service representative will authorize the return and make arrangements to replace the defective parts. This is your sole GEARGRID warranty. GEARGRID disclaims all other warranties, including the warranty of merchantability and fitness for a particular purpose, as well as all liability for incidental, consequential, special and indirect damage. GEARGRID liability shall be limited to the amount you paid for the product under warranty. GEARGRID reserves the right to make product changes without obligation to incorporate such changes into products previously sold. Some states do not allow the exclusion or limitation of damages or warranties, so the above may not apply to you. This warranty gives you specific legal rights. You may also have other rights which may vary from state to state. GEARGRID products are covered by U.S. patents: 6,241,107; D 636,202; D 635,810



THANK YOU FOR CHOOSING GEARGRID for smarter, stronger, storage solutions.
Setting the standard for craftsmanship, quality, and service.

For general parts or assembly assistance: 651-464-4468 or toll free 888-643-6694

For accessory inquiries: sales@geargrid.com or 651-464-4468, toll free 888-643-6694

For our versatile product line, specifications and resources for custom solutions: www.geargridcorp.com

PROPRIETARY AND CONFIDENTIAL: THE INFORMATION CONTAINED IN THESE INSTRUCTIONS ARE THE SOLE PROPERTY OF GEARGRID LLC. ANY REPRODUCTION IN PART OR AS A WHOLE WITHOUT THE WRITTEN PERMISSION OF GEARGRID CORPORATION IS PROHIBITED.

670 SW 15th Street, Forest Lake, MN 55025 | Toll Free: 888-643-6694 | 651-464-4468 | Fax: 651-464-4780
sales@GearGrid.com | www.geargridcorp.com





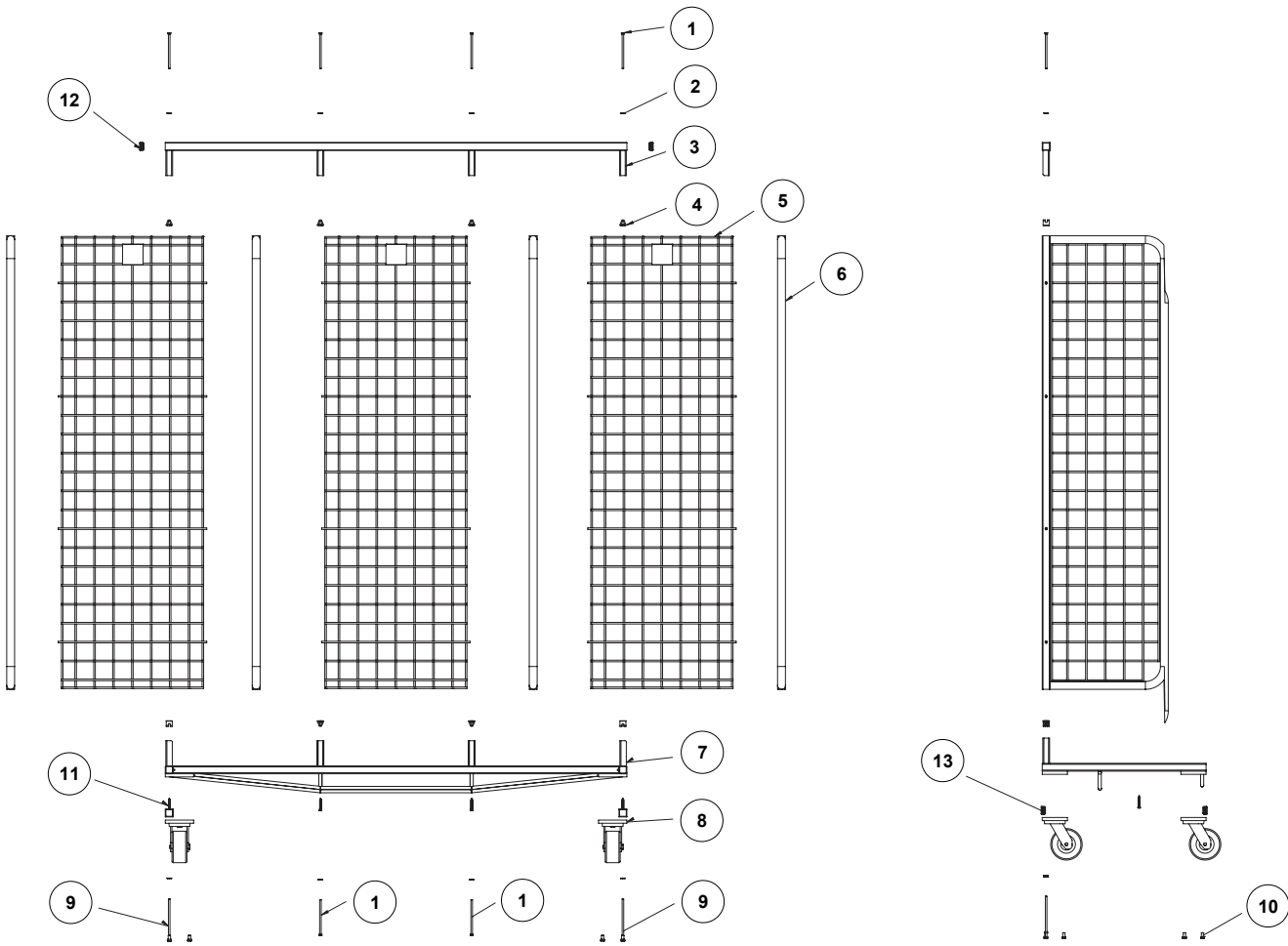

Parts

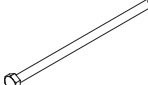
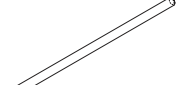

Below you will see an exploded view of the **Heavy Duty Mobile Hose/SCBA Bottle Storage Unit**. Use this view along with the parts list to aid in assembly of the unit.

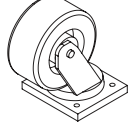
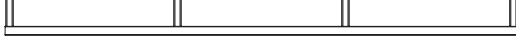
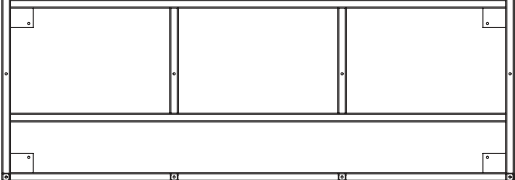
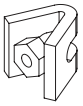
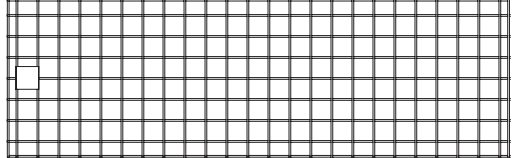
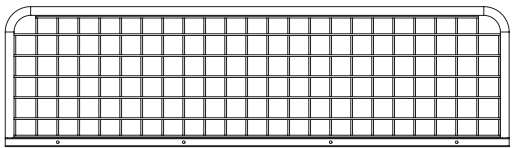

Below is the part list that correlates with the exploded view.

						
1 1/4-20 X 5-1/2" BOLT	9 1/4-20 X 6-1/2" BOLT	11 # 14 SCREW	2 1/4" WASHER	10 3/8-16 X 5/8" BOLT	12 1-1/4" X 16 GA. PLUG	13 1-1/4" X 11 GA. PLUG
						
8 HEAVY DUTY CASTER	3 3-START TUBE			7 BASE		
						
4 WEDGE NUT	5 BACK PANEL			6 SIDE PANEL		

STEPS

- | | |
|------------------------------|---|
| 1) Assemble base hardware | 4) Assemble 3-start tube hardware and install to unit |
| 2) Mount side panels to base | 5) Fasten side panels to base |
| 3) Install back panels | 6) Shelf installation |

1) Assemble Base Hardware

Step 1a: Locate the base and position it on its side as shown. Install the casters using the supplied 3/8 bolts qty- 14, leave the holes open where the C-channels are located.

Step 1b: Now use the 1/4 x 6-1/2" bolts, washers and wedge nuts for the holes that line up with the C-channels qty-2. Do not tighten at this time.

Step 1c: Assemble the 1/4 x 5-1/2" bolts, washers and wedge nuts to the center C-channels qty-2. Do not tighten at this time.

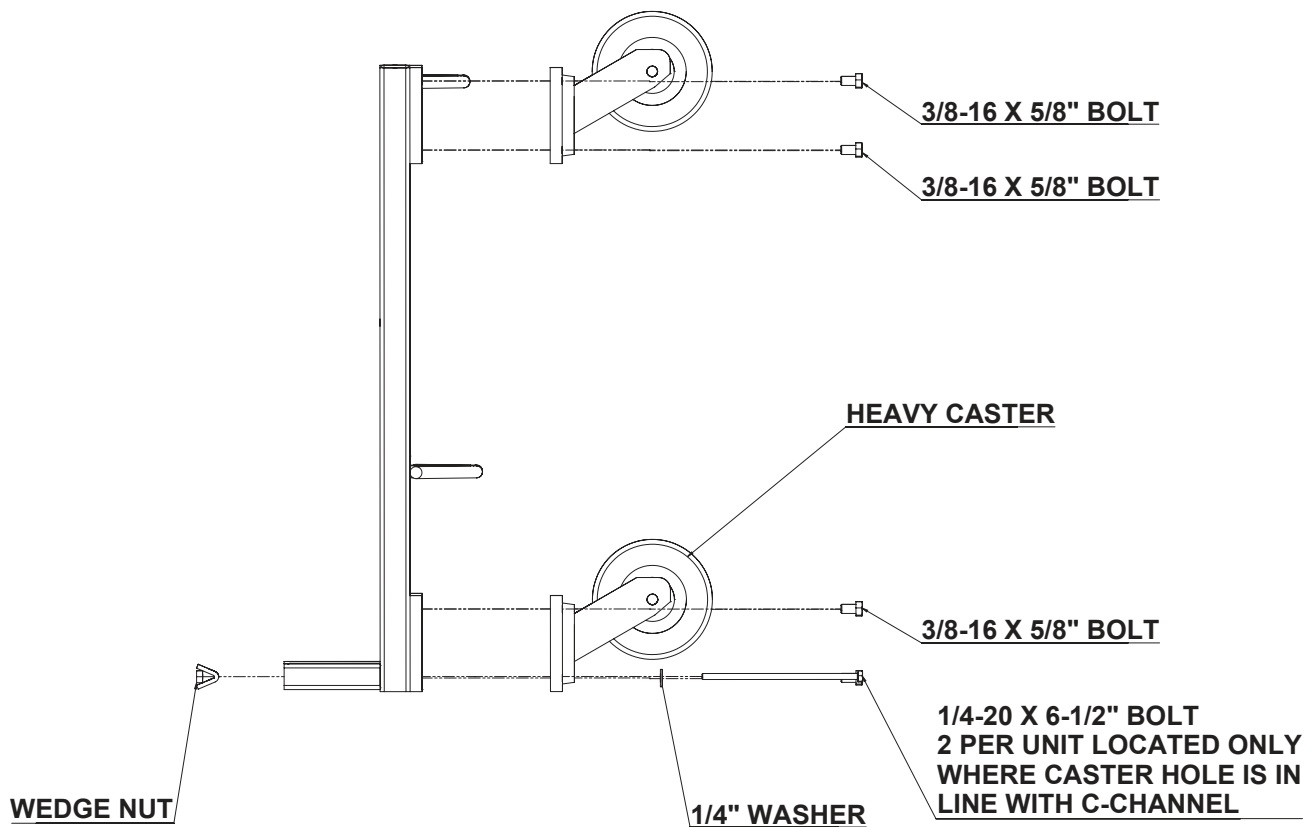

2) Mount Side Panels to Base

Step 2a: Position the side panel so the hole on the bottom of the round tube is located at the base and the short wires are facing right. Slide the side panel over the U-Channel as shown. Do not slide the side panel all the way down at this point. **Ensure the side panels short wires are all facing right. The shelves will not fit properly if the sides are oriented incorrectly.** Install the remaining side panels.

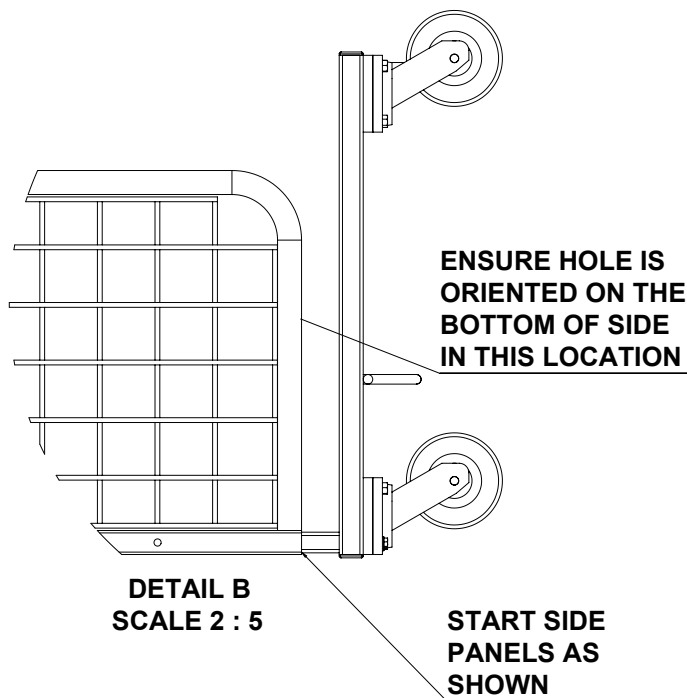
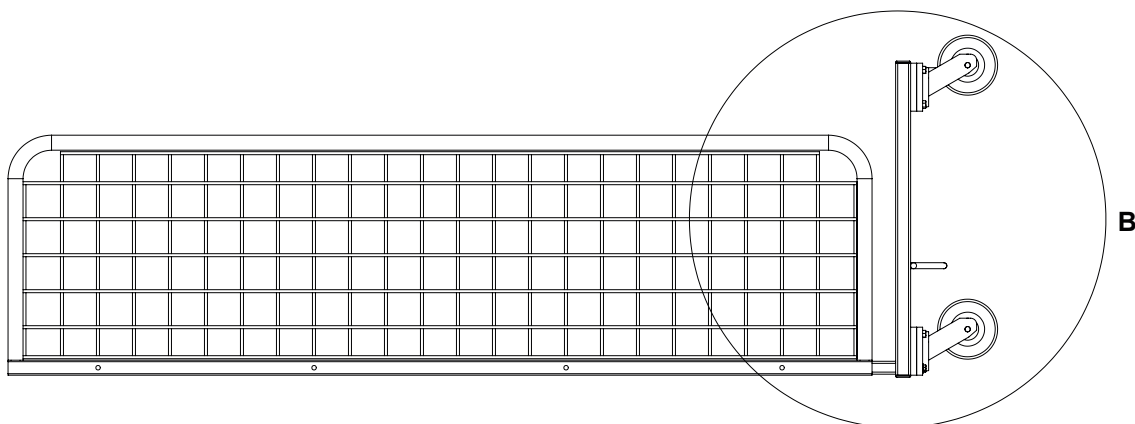

3) Install Back Panels

Step 3a: Slide the side panels out far enough to allow the back panel to be placed into position. The extended wires on the back panels will mate into the holes on the side panel tubes. Place all panels into position with the Geargrid logo at the top and the short horizontal wires facing up.

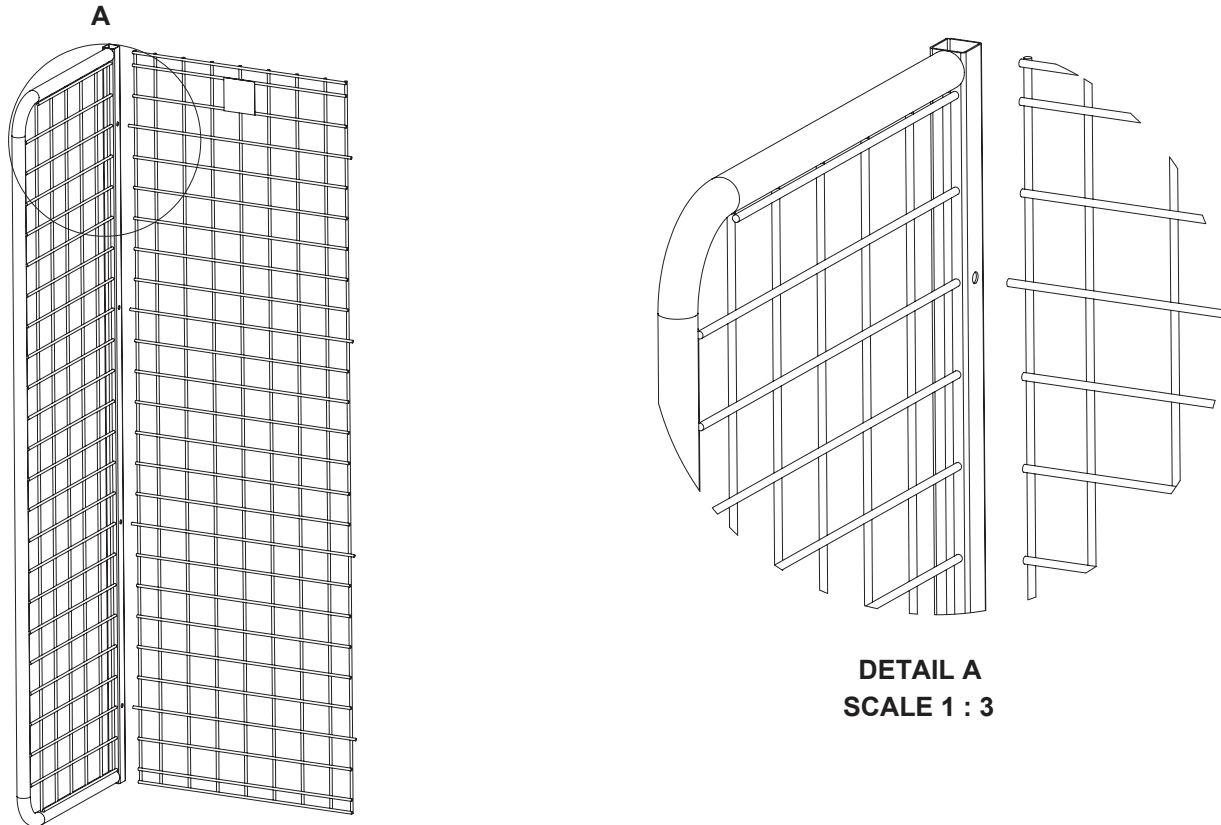

4) Assemble 3-start Tube Hardware and Install to Unit

Step 4a: With the sides and back panels installed it is now time to seat the sides down on top of the base.

Step 4b: Assemble the three start tube with hardware as shown below.

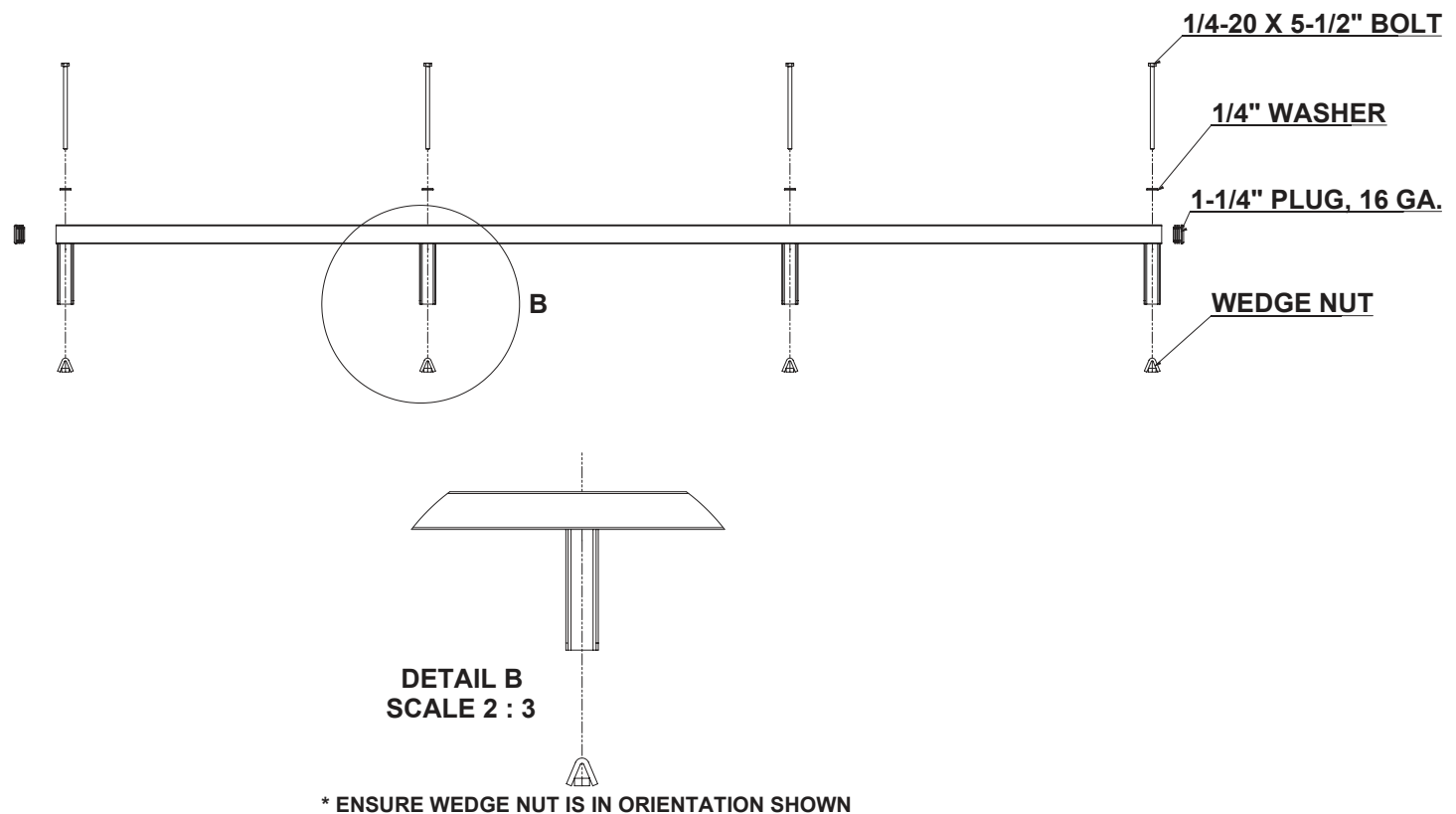

Step 4c: Install the assembled three start tube to the top of the unit by sliding the C-Channels into the side tubes. Tighten both top and bottom 1/4" bolts, do not over tighten as tube deformation will occur.

5) Fasten the Side Panels to the Base

Step 5a: Install the #14 sheet metal screws up through the bottom of the base and into the bottom of each side panel. Tighten these screws. Stand the unit up on its casters for shelf installation.

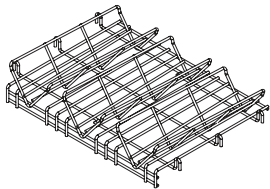

SCBA SHELF
QTY - PER ORDER

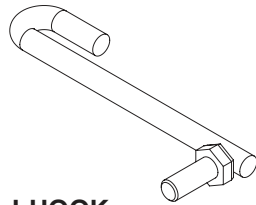

J-HOOK
QTY - 2

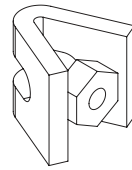

WEDGE NUT
QTY - 4

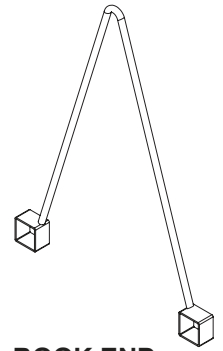

BOOK END
QTY - PER ORDER

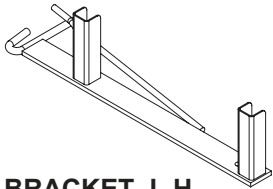

BRACKET, L.H.
QTY - 1

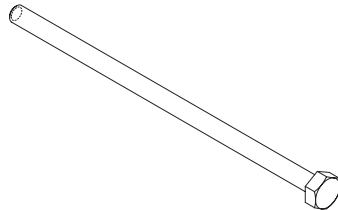

1/4-20 X 4-1/2" BOLT
QTY - 4

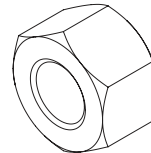

5/16-18 NYLOCK NUT
QTY - 2

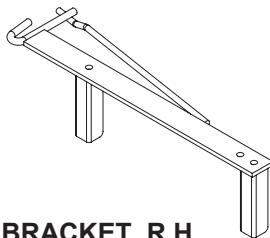

BRACKET, R.H.
QTY - 1

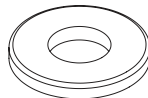

1/4" WASHER
QTY - 4

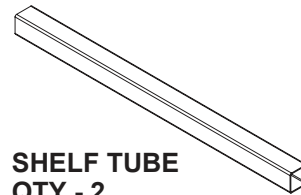

SHELF TUBE
QTY - 2

6) Shelf Installation

Step 6a: Install the SCBA shelves into the unit as shown in the diagram below. The hooks on the shelves get placed over the horizontal wires on the side panels. The left side hook will be placed behind the first vertical wire. The right side hook will be placed in front of the first vertical wire.

DETAIL B
SCALE 1 : 1

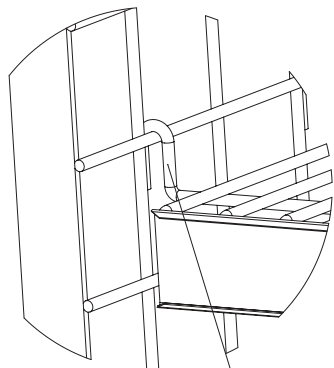

LEFT SIDE OF SHELF
THE SHELF WIRE GOES BEHIND
THE FIRST VERTICAL WIRE

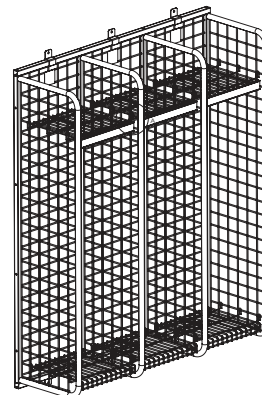
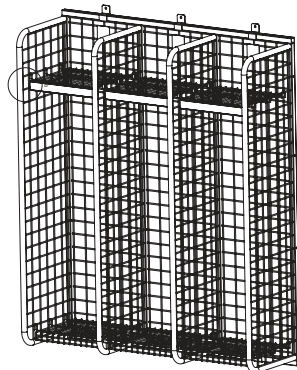

DETAIL A
SCALE 1 : 1

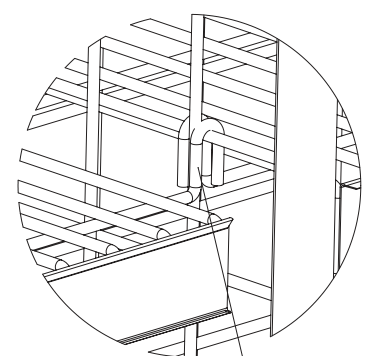

RIGHT SIDE OF SHELF
THE SHELF WIRE GOES IN FRONT
OF FIRST VERTICAL WIRE

Step 6b: Assemble the hose shelf per the diagram below.

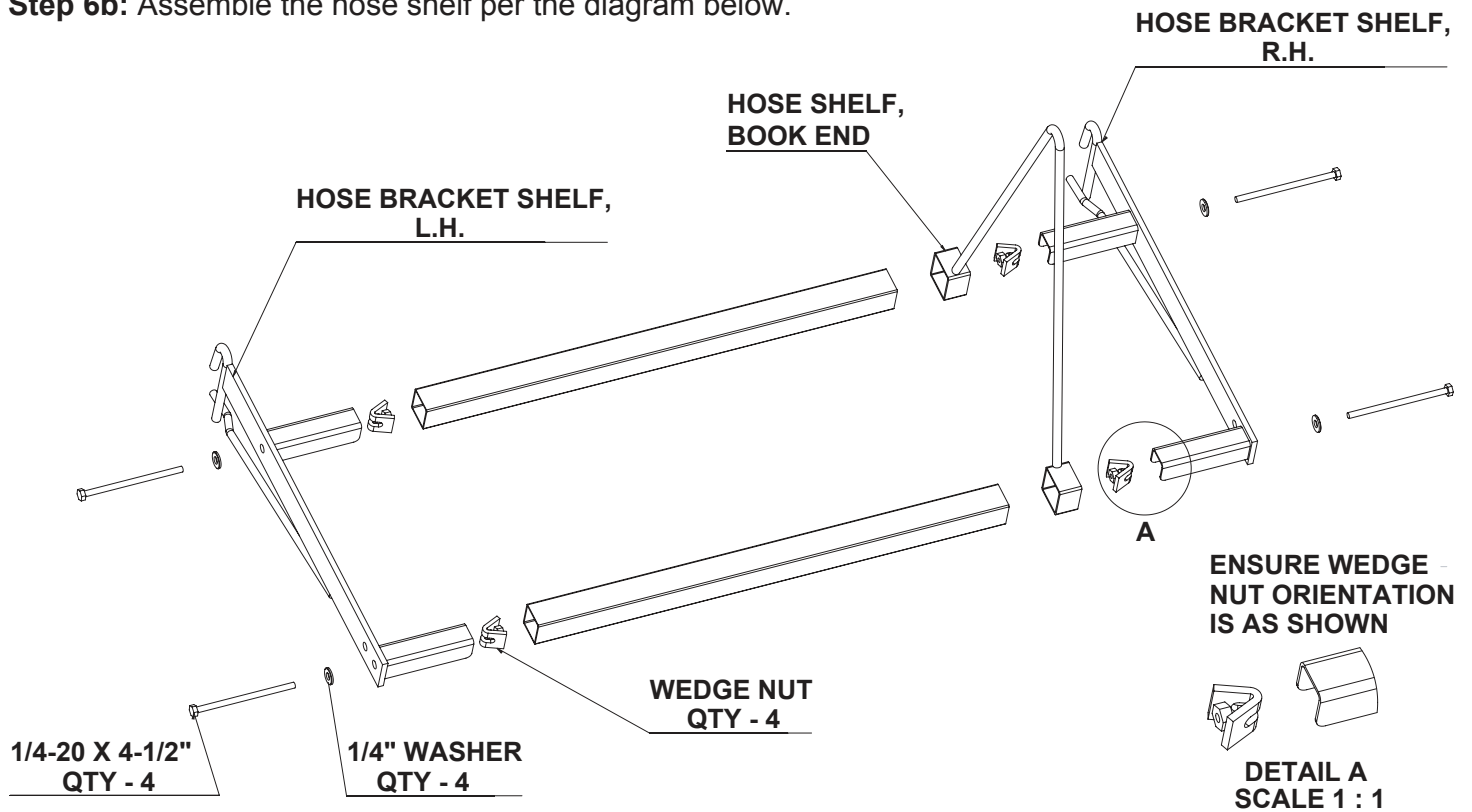

Step 6c: Install the assembled hose shelf by hooking it to the back panel on the unit. Take one J-Hook and a nylock nut and fasten to side panel wire towards the front through the hole in the hose shelf bracket. Install the second J-Hook on the other side the same way.

